



A235-300

*The lowest cost proven
Tactical Airlifter*

*Combat proven with
NATO allies*

- Autonomous operation and fully interoperability with CH-47 and C-130
- Successful Surveillance Version
- Commonality benefits
- +250 aircraft sold, 39 Operators, + 1,000,000 flights

EADS
MILITARY TRANSPORT
AIRCRAFT

C-23530



The response to the current needs



Constant cross section along cabin

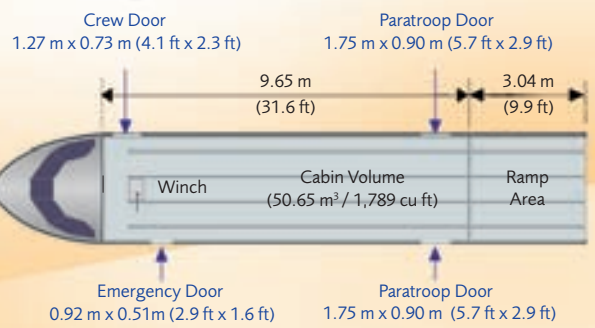
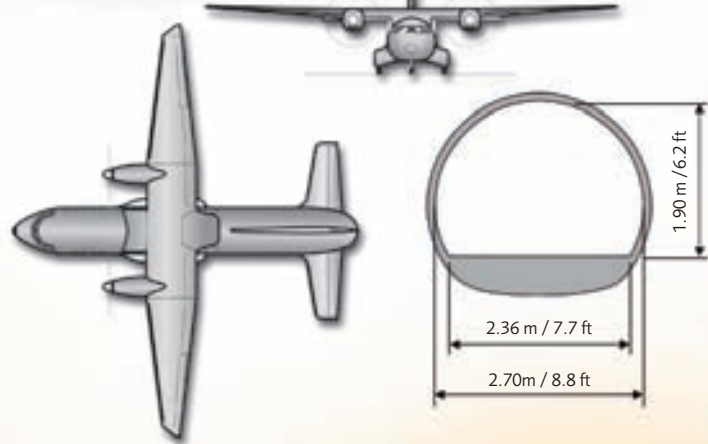

Always Available

Main Dimensions

Overall Length:	21.40 m	70 ft 2 in
Overall Height:	8.17 m	26 ft 8 in
Wing Span:	25.81 m	84 ft 8 in
Wheel Track:	3.90 m	12 ft 8 in
Wheel Base:	6.92 m	22 ft 9 in

Weights

Maximum Take Off Weight:	16,500 kg	36,380 lb
Maximum Landing Weight:	16,500 kg	36,380 lb
Maximum Payload*:	5,950 kg	13,120 lb
Usable Fuel Capacity:	5,220 litres	1,380 USg

Performance

Maximum Cruise Speed (TAS):	452 km/h	244 kt
Normal Operating Altitude:	7,620 m	25,000 ft
Ferry Range:	5,060 km	2,730 nm
Range with 5,000 kg	1,800 km	970 nm
Take Off run (ISA, S/L, 16,500 kg):	404 m	1,325 ft
Landing roll (ISA, S/L, 16,500 kg):	378 m	1,240 ft
Load Factor Limits:	3.0 g/-1.0 g	

Power Plant

Engines: 2 General Electric CT7-9C3 of 1,750 shp each
 Propellers: Hamilton Sundstrand 14RF-37



* Depending on the configuration selected.

Military Transport Aircraft

Avda. de Aragón, 404, 28022. Madrid (Spain)
 Tel.: +34 91 585 73 62 - Fax.: +34 91 585 73 66 - e-mail: sales@casa.eads.net
 Website: www.eads.net
 © EADS CASA ALL RIGHTS RESERVED
 January, 2008

The statements made herein do not constitute an offer. They are based on the assumptions shown and are expressed in good faith. Where the supporting grounds for these statements are not shown, EADS CASA will be pleased to explain the basis thereof.

Superior Mission flexibility



Four 88" x 108" standard pallets (one on the ramp)



36 Fully Equipped Troops

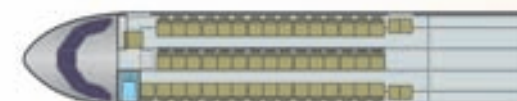

51 Training Troops

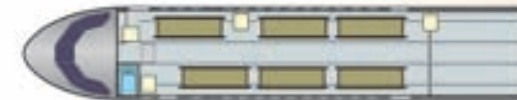

18 Stretchers + 4 medical attendants



4x4 Vehicle Transport

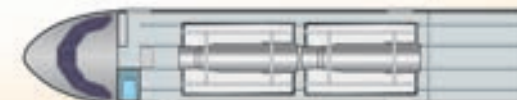

Fighter engines, helicopter blades



40 passengers at 30" pitch

