

# C212<sup>400</sup>

C-212, beyond the  
Last Frontier

*...the leader in its class*

- ...Desert, jungle, Antarctic...
- C-212 wherever you need it
- Upgraded versatility
- + 500 aircraft, + 90 operators, + 3,000,000 flight hours

 **EADS**  
MILITARY TRANSPORT  
AIRCRAFT

# C212400



## The leader

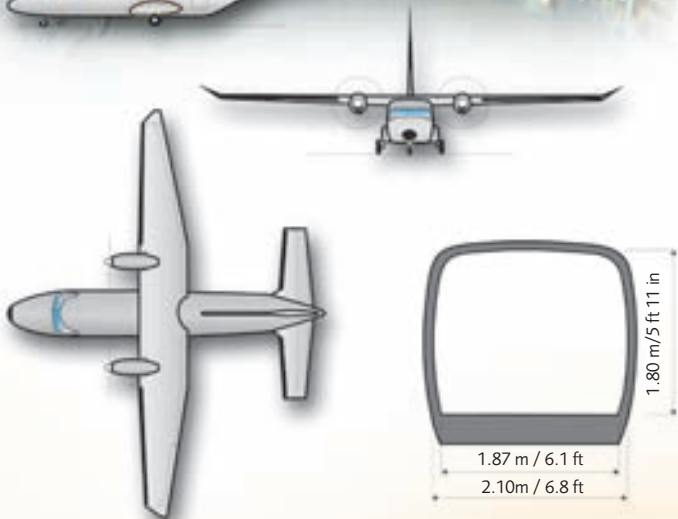

Emergency Exit  
0.687 m x 0.548 m (5.7 ft x 2.9 ft)

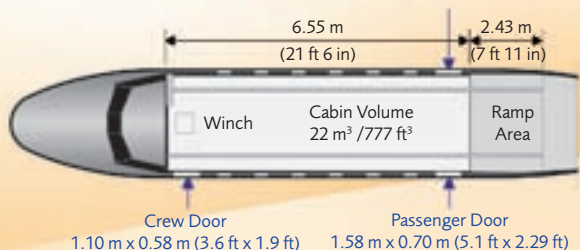

## Noteworthy evolution

### Main Dimensions

Overall Length:	16.15 m	53 ft
Overall Height:	6.59 m	21 ft 7 in
Wing Span:	20.27 m	66 ft 6 in
Wheel Track:	3.10 m	10 ft 2 in
Wheel Base:	5.45 m	17 ft 10 in

### Weights

Maximum Take Off Weight:	8,100 kg	17,857 lb
Maximum Landing Weight:	8,100 kg	17,857 lb
Maximum Payload*:	2,800 kg	6,172 lb
Usable Fuel Capacity:	2,000 litres	528 USg
External tanks	1,000 litres	264 USg

### Performance

Maximum Cruise Speed:	360 km/h	195 kt
Maximum Operating Altitude:	7,620 m	25,000 ft
Ferry Range:	1,690 km	913 nm
Take-off Distance (S/L, ISA, MTOW):	590 m	1,935 ft
Landing Distance (S/L, ISA, MTOW):	520 m	1,705 ft
Maximum Range (With external tanks):	2,465 km	1,330 nm
Range with 2,000 kg payload (4,000 lb):	1,325 km	715 nm

### Power Plant

Engines 2 x Allied Signal TPE331-12JR of 925 SHP each  
Propellers Dowty Rotol R. 334/4-82-F (four bladed)

### Avionics

The C-212-series 400 incorporates a new integrated avionics system, with data presented in four EFIS displays, reducing pilot workload and improving flight awareness.



\* Depending on the configuration selected.

## Unmatched experience



Two 88" x 54" standard pallets

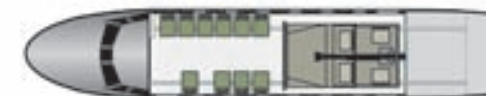

10 Troops + Vehicle Transport



25 Troops



12 stretchers + 4 Medical Attendants



HAD or LAPES



Fighter engines, helicopter blades



19 Passengers Transport

### Military Transport Aircraft

Avda. de Aragón, 404, 28022. Madrid (Spain)

Tel.: +34 91 585 73 62 - Fax.: +34 91 585 73 66 - e-mail: sales@casa.eads.net

Website: www.eads.net

© EADS CASA ALL RIGHTS RESERVED

January, 2008



The statements made herein do not constitute an offer.  
They are based on the assumptions shown and are expressed in good faith.  
Where the supporting grounds for these statements are not shown, EADS CASA will be pleased to explain the basis thereof.